

# UST PRO v2.0

The UST PRO device is designed for emergency unlocking, locking, starting, and programming of the **latest-generation** TOYOTA/LEXUS smart keys for **2022-2026 model year vehicles**.

## DEVICE PRINCIPLE & ALGORITHM

1. Connect UST PRO to the vehicle CAN bus;
2. Read data from the vehicle (READ DATA);
3. Write read data to the key emulator (EMU/KEY).
4. Use the emulator for emergency unlocking, locking, starting, and programming additional smart keys.



## The main advantages of the device compared to existing analogues

- the ability to work with latest-generation vehicles that use HITAG BA type keys;
- the presence of an external emulator with all the functions of the original key;
- possibility of adding original used keys (aftermarket, OEM).

## SUPPORTED CAR MODELS

**TOYOTA / LEXUS:** models from **2021** to **2026** (Europe, USA, Asia/Japan)

**SUPPORTED KEYS:** **BA, B8, B9, HTBA** (Hitag BA).

- Original keys (aftermarket, OEM);
- Chinese (non-original) keys prepared as the corresponding original key.

## THE KIT

- UST PRO v2.0;
- Cable with needle probes (for connection to the CAN bus);
- Adapter for connection to Smart ECU;
- OBD cable (for connection to OBD);
- Key emulator;
- Mini-USB cable for PC updates and power supply via a power bank (not included).



### **DEVICE CONNECTION OPTIONS**

- Smart ECU - use a cable with needle probes or the adapter (all models)
- Headlight control unit - use a cable with needle probes (Lexus NX until 02/2023 and others);
- MND ECU (Multiplex Network Door ECU) - trunk unit - use a cable with needle probes (all models);
- OBD - use the OBD cable (for adding new keys and deleting outdated ones on all models).

**Attention!** *When using a cable with needles for CAN bus connection, the device must be powered from an external power source (Power Bank) via the mini-USB port.*

### **ОРГАНЫ УПРАВЛЕНИЯ:**

1. Display;
2. Confirm button;
3. Up navigation button;
4. Down navigation button;
5. Back button;
6. Mini USB port;
7. Coil location.



## DEVICE OPERATION (Step-by-Step Instructions)

The device powers on automatically when supplied with power via a power bank or a Smart ECU adapter. The device version is briefly shown on the display, after which the main menu appears.

### Startup Menu

In the startup menu, use the control buttons to select the required key type. After selecting the key type, the main menu will be displayed on the screen.

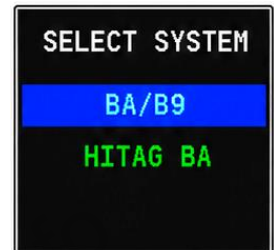

### Main Menu

- READ DATA
- WRITE EMU
- ADD KEY
- ERASE KEY
- UTILS

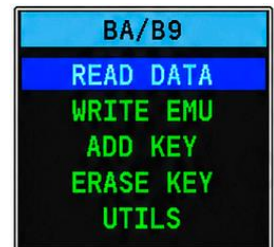

#### ➤ READ DATA (чтение данных)

1. Connect the needle probes to the CAN bus (**power supply via a power bank**) or use the Smart ECU adapter (**does not work via OBD!!!**).
2. Select **READ DATA**. Wait 15-20 seconds.
3. After successful reading, the screen will display:

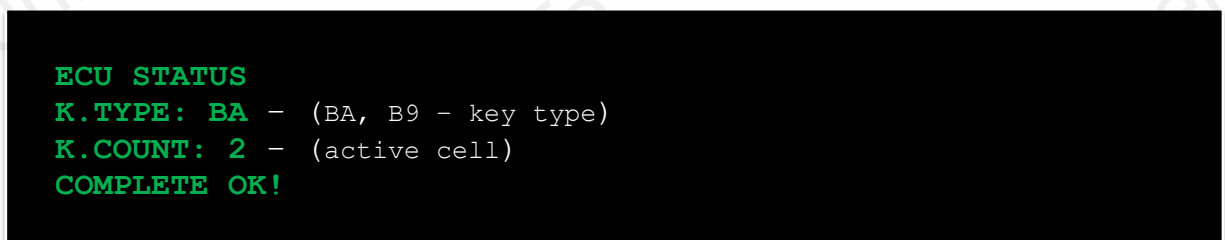

4. All data is stored in NVM (non-volatile memory). There is no need to read the same module again.

#### ➤ WRITE EMU (writing to the emulator)

1. Select **WRITE EMU**.
2. Select the region for keyless-Go and remote:

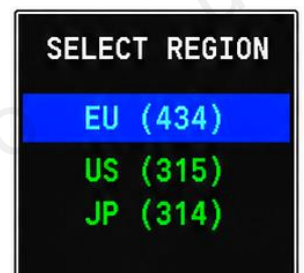

3. The following will appear on the screen:

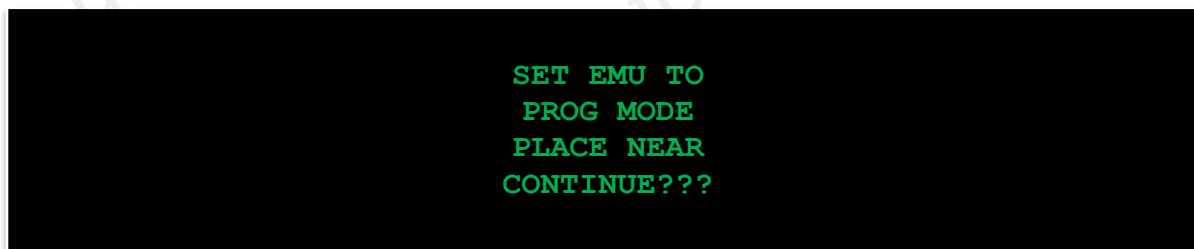

4. Switch the emulator to programming mode by holding both buttons for 3 seconds. The LED will start blinking. At the same time, previous vehicle data is deleted.
5. Place the emulator near the coil and press the **OK** button to start writing.

*Note! If the LED remains on during programming and the key emulator fails to program, reset the emulator by removing and reinstalling the battery, then repeat the programming procedure.*

➤ **ADD KEY**

(Be sure to perform **READ DATA** first !!!)

1. Connect the needle probes to the CAN bus (**power supply via a power bank**) or use the Smart ECU adapter, or connect the device to OBD2 port via the appropriate adapter.
2. Turn on the ignition.
3. Select ADD KEY. Wait 5-10 seconds.
4. After connection, the following will appear on the screen:

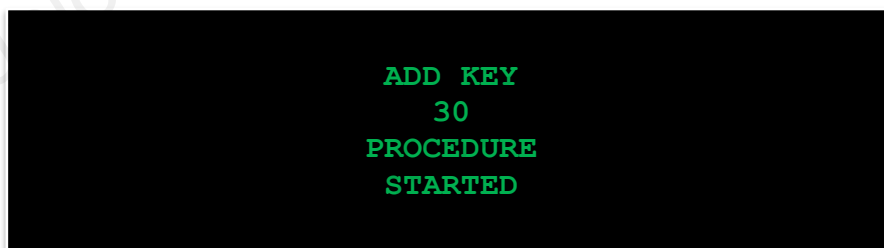

**30 - (maximum time in seconds to complete the procedure)**

5. Within 30 seconds, place the working key (or key emulator containing the vehicle data read earlier) near the Start/Stop button. The sound signal will confirm successful recognition.
6. Within 30 seconds, place the new key (aftermarket, original or non-original) near the Start/Stop button - the sound signal will be heard.

**Repeat step 6 for the remaining keys**

7. Wait for the time to expire or press the **BACK** button on the device to exit manually.

- Press the buttons on the new key several times to synchronize the buttons.

➤ **ERASE KEY**

(Be sure to perform **READ DATA** first !!!)

- Connect the needle probes to the CAN bus or use the Smart ECU adapter, or connect the device to the OBD2 port via the appropriate adapter.
- Turn on the ignition.
- Select **ERASE KEY**. Wait 5-10 seconds.
- After connection, the following will appear on the screen:

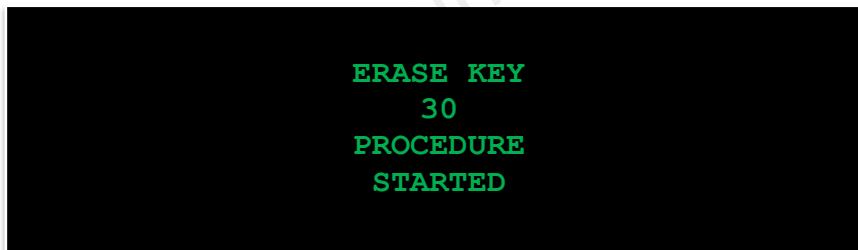

30 - (maximum time in seconds to complete the procedure)

- Within 30 seconds, place each key that should remain active near the device one by one – an audible signal will confirm recognition.  
**All other keys will be erased!!!**
- Wait for the time to expire or press the **BACK** button to exit.

➤ **UTILS**

Additional functions for working with the key.

**UTILS submenu**

- **CHECK KEY**
- **RESET KEY**
- **CREATE EMU**
- **UPDATE EMU**

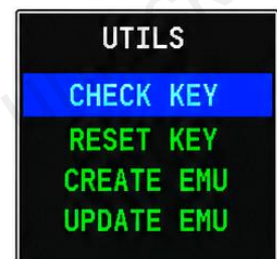

➤ **CHECK KEY (key type identification)**

- Select **CHECK KEY**
- The following will appear on the screen- "PLACE KEY NEAR COIL".
- Place the emulator near the coil.



4. The message will appear on the screen, for example:

```
BA - (key type: BA/B9/Hitag BA)
USED - (key status: USED/NEW)
OEM - Key version: original (OEM) / analog (aftermarket)
=LEXUS= - model type
```

➤ **RESET KEY**

Changing the key status from USED to NEW (restoration).

**After this, the key will stop working in the keyless-go system!!!**

1. Select **RESET KEY**
2. The message will appear on the screen:

```
PLACE
ORIGINAL
USED KEY
NEAR COIL
```

3. Place the key near the coil and wait for the procedure to complete.

➤ **CREATE EMU** (key emulator creation)

This procedure is required when you need to add an original (OEM) key to the system using the key emulator.

1. Select **CREATE EMU**.
2. The message will appear on the screen:

```
ADD KEY
30
PROCEDURE STARTED
```

```
CREATE EMU
PLACE ORIGINAL
OEM KEY
NEAR COIL
```

3. Place the ORIGINAL (OEM) key that needs to be added to the system near the coil!!!
4. The message will appear on the screen (example):

```
DETECTED
=LEXUS=
TRANSPONDER
CONTINUE???
```

5. Place the key near the coil and press **OK** button on the device.
6. The message will appear on the screen:

```
SET EMU TO
PROG MODE
PLACE NEAR
CONTINUE???
```

7. Put the original (OEM) key aside!!!
8. Set key emulator to programming mode by holding both buttons for 3 seconds - the LED will start blinking.
9. The message will appear on the screen:

```
USE EMU
INSTEAD OF
ORIGINAL KEY
WHEN ADDING!!!
```

After this, the emulator will contain the created **AFTERMARKET** key.

10. Return to the main menu.
11. Connect the needle probes to the CAN bus (**power supply via a power bank**) or use the Smart ECU adapter, or connect the device to the OBD2 port via the appropriate adapter.
12. Select **ADD KEY**. Wait 5-10 seconds.
13. After connection, the following will appear on the screen:

```
ADD KEY
30
PROCEDURE STARTED
```

```
BA/B9
ADD KEY
CONNECTION
..
```

30 - (maximum time in seconds to complete the procedure)

14. Within 30 seconds, place the working key (or key emulator registered to the vehicle) on the Start/Stop button – the sound signal will be heard.
15. Within 30 seconds, place the **EMULATOR** containing the data of the original OEM key (see steps 3-9 of this section) on the Start/Stop button – the sound signal will be heard.
16. Wait for the time to expire or press the right button on the device to exit the procedure manually.  
Put the **EMULATOR** aside!!! **Further use of this emulator is not permitted, as it may lead to loss of the key!!!**
17. On the remote of the **original OEM key previously added to the system**, press the buttons several times to synchronize them (see steps 3-9 of this section).

➤ **UPDATE EMU**

1. Switch the emulator to programming mode (hold both buttons for 3 seconds) – the LED will start flashing.
2. Place the emulator near the coil and press **OK** button to start writing.

**DEVICE CONNECTION POINTS**

In the case when the car is armed and all doors are closed, access to the CAN bus is possible only:

1. By connecting via the left headlight control unit connector (Lexus NX until 02/2023 and etc.)

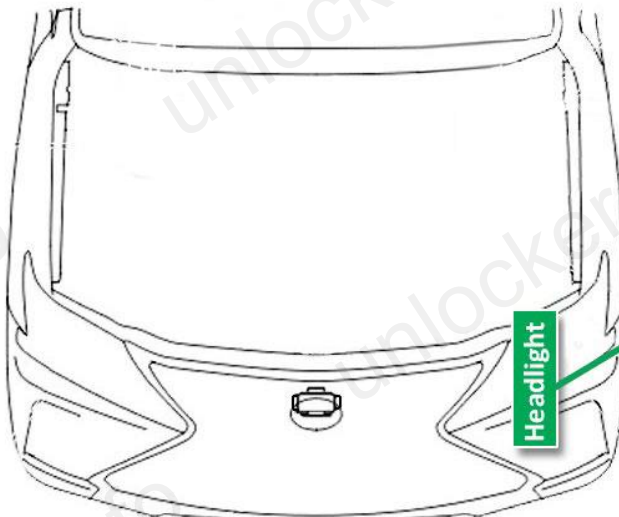

■ CAN - HIGH  
■ CAN - LOW

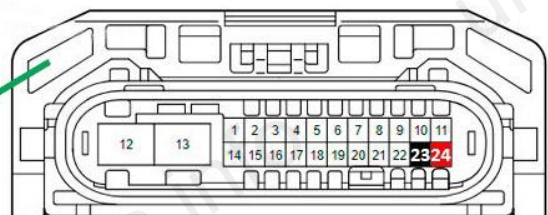

2. By connecting via the MND ECU (Multiplex Network Door ECU) tailgate control module connector. From 02/2023, access to the headlight control unit is impossible because the manufacturer has made changes to the vehicle's electrical circuit. Therefore, it is necessary to make a hole opposite the MND ECU connector and connect the needles to connector g28, pin 10 (**CAN HI**) and pin 20 (**CAN LOW**).

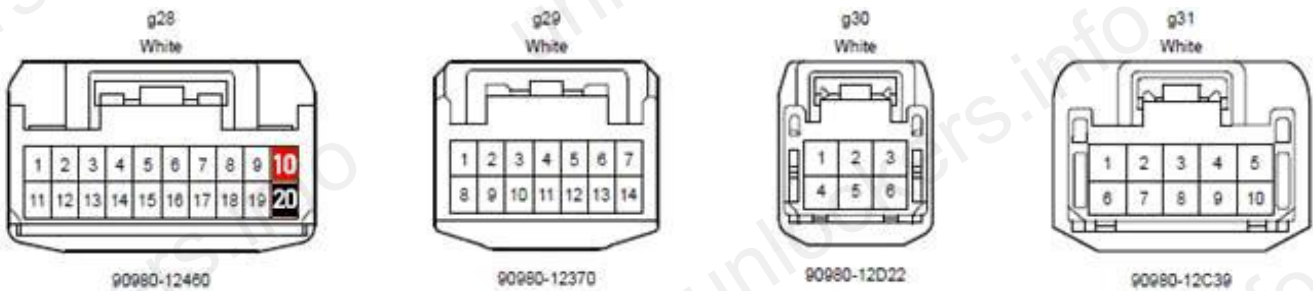

**Module connectors of Multiplex Network Door ECU (tailgate control module).**

- If the trunk door isn't automatic and the MND ECU block is missing, other connection points inside the vehicle are required for access. This situation is possible in simple Toyota models, in Lexus cars the MMD ECU unit is usually installed.
- Depending on the vehicle configuration, other connection points are possible (in doors, Body ECU, Smart ECU, etc.). In such cases, it is necessary to study the car's electrical circuits, and the locations of its electronic blocks, wiring, and connection sockets.

3. By connection via special adapter to Smart ECU.

Blue wire (pin 1) ← red probe Can High)  
Black wire (pin 2) ← black probe (Can Low)

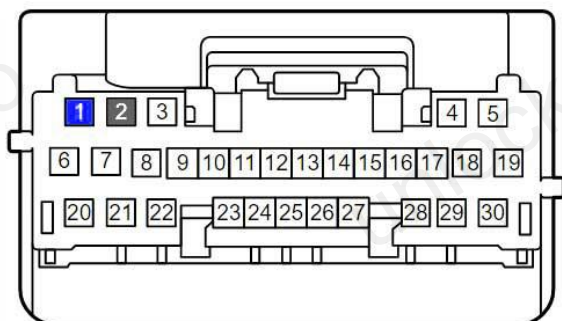

**Smart ECU module connectors**

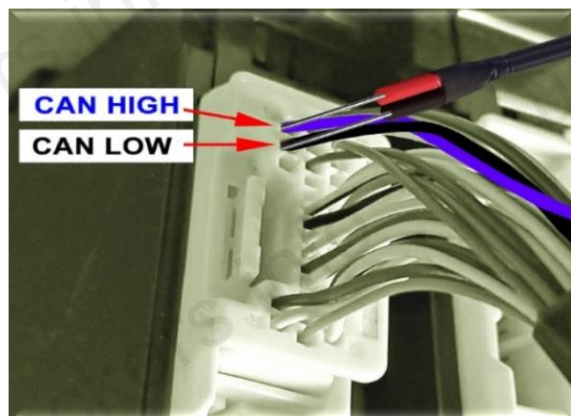

A1) Connection points for Lexus LX

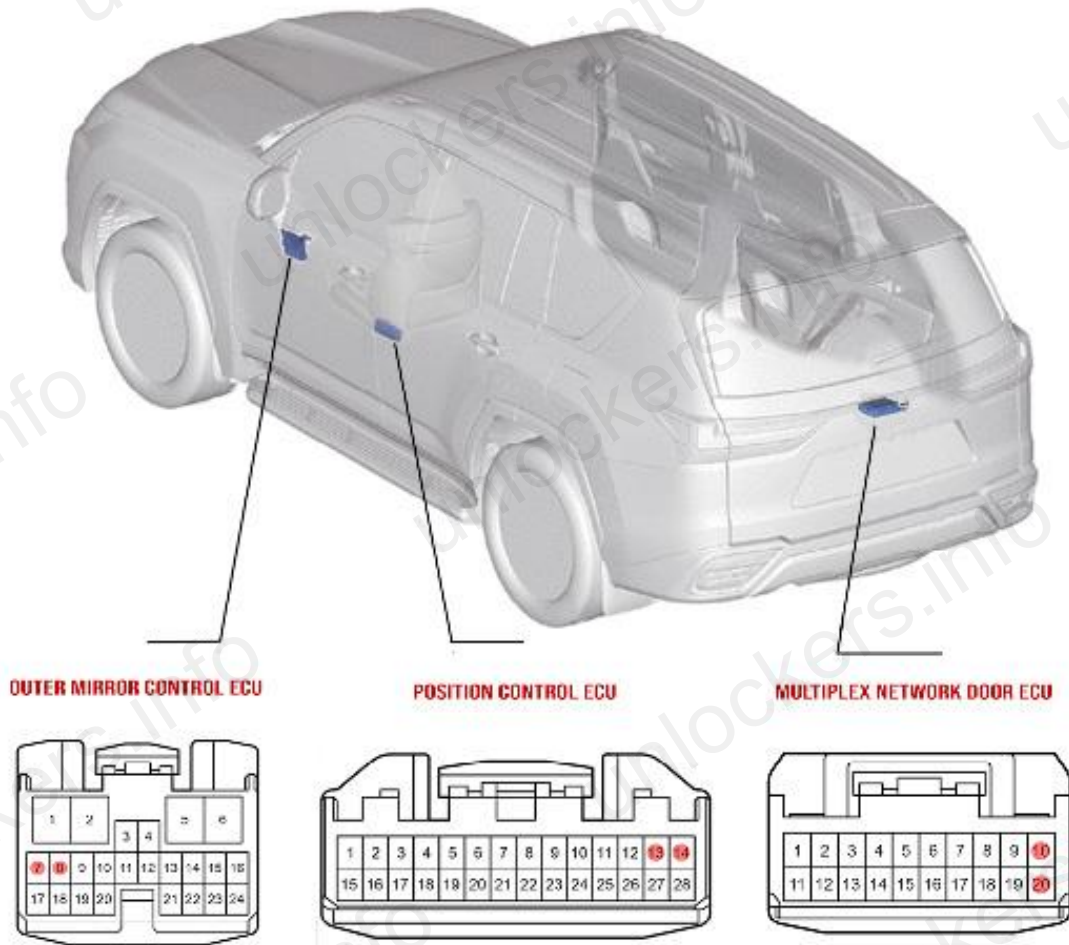

A2) Connection points for Lexus RX

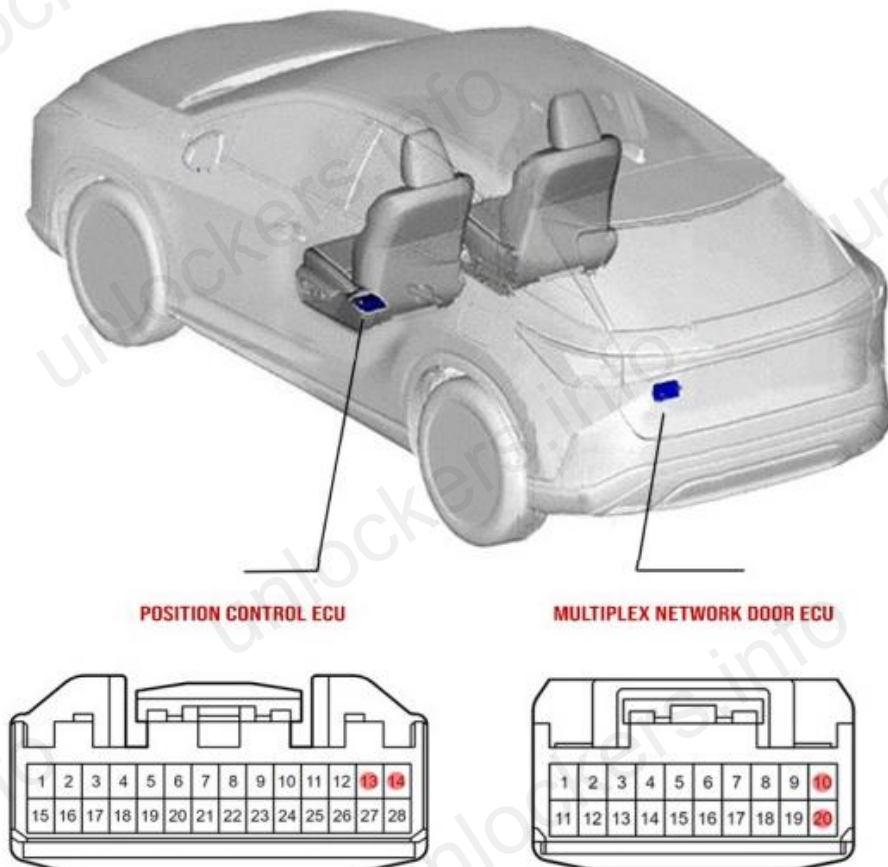

A3) Connection points for Lexus NX



**HEADLIGHT**

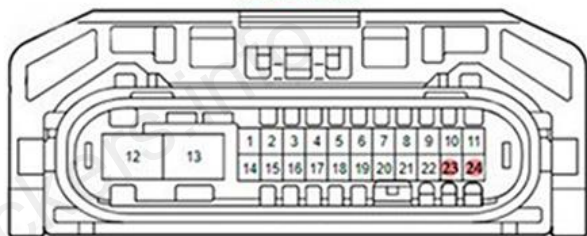

**MULTIPLEX NETWORK DOOR ECU**

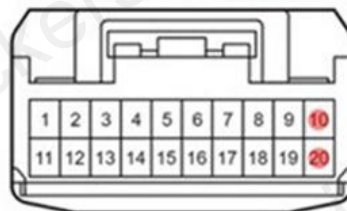

A4) Connection points for Lexus GX

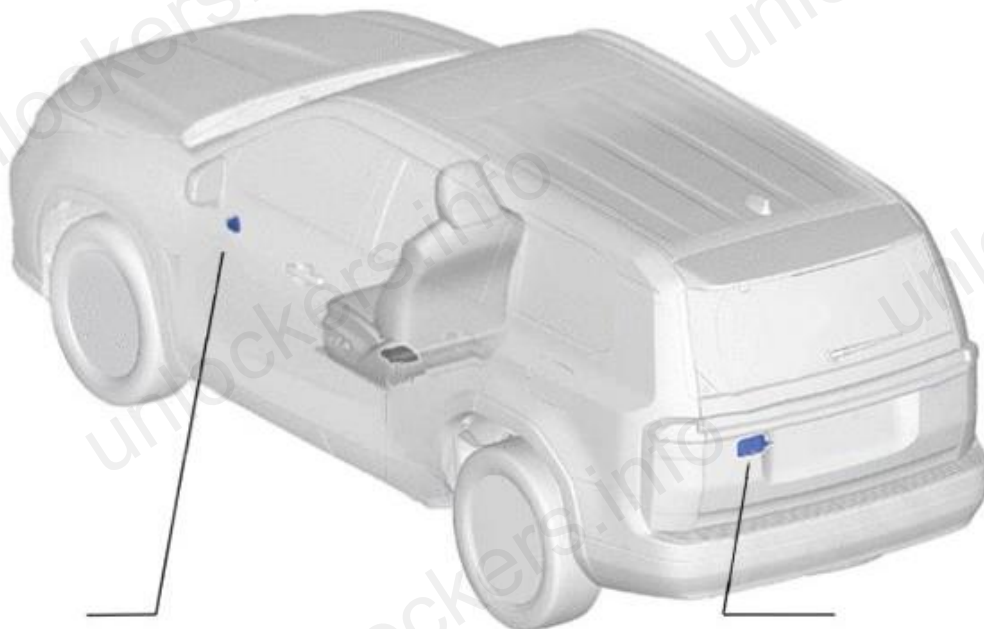

**OUTER MIRROR CONTROL ECU**



**MULTIPLEX NETWORK DOOR ECU**

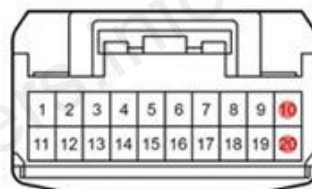

A5) Connection points for Lexus RZ

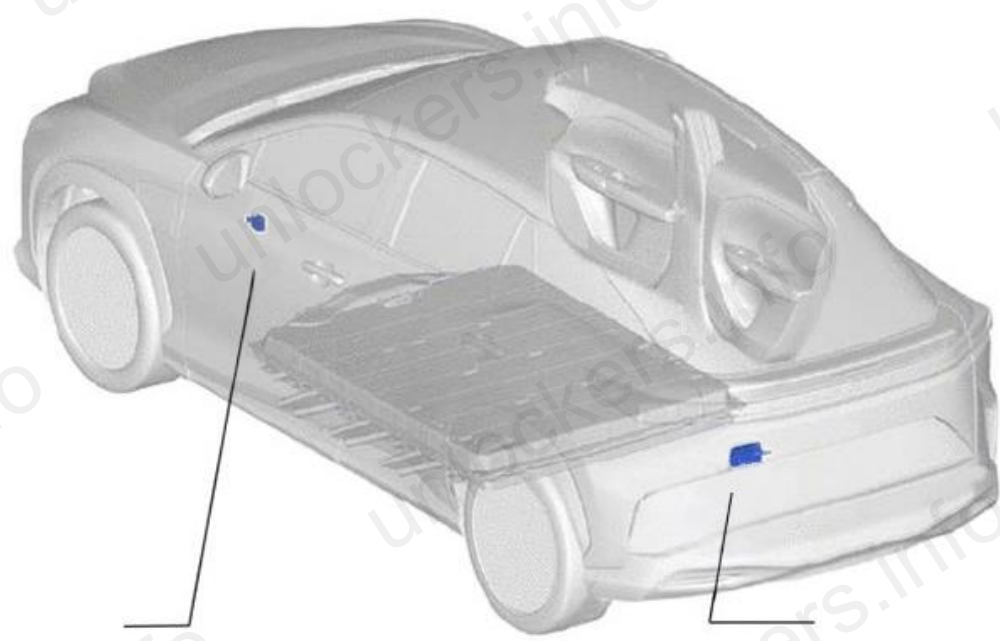

**OUTER MIRROR CONTROL ECU**



**MULTIPLEX NETWORK DOOR ECU**

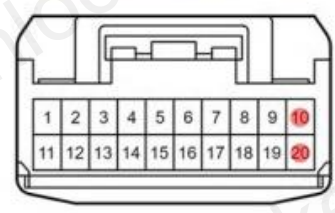

A6) Connection points for Lexus LBX



**MULTIPLEX NETWORK DOOR ECU**

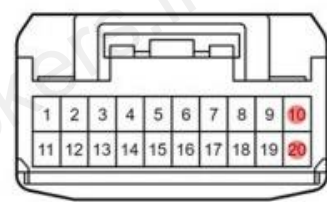

A7) Connection points for Lexus LM / Toyota Alphard

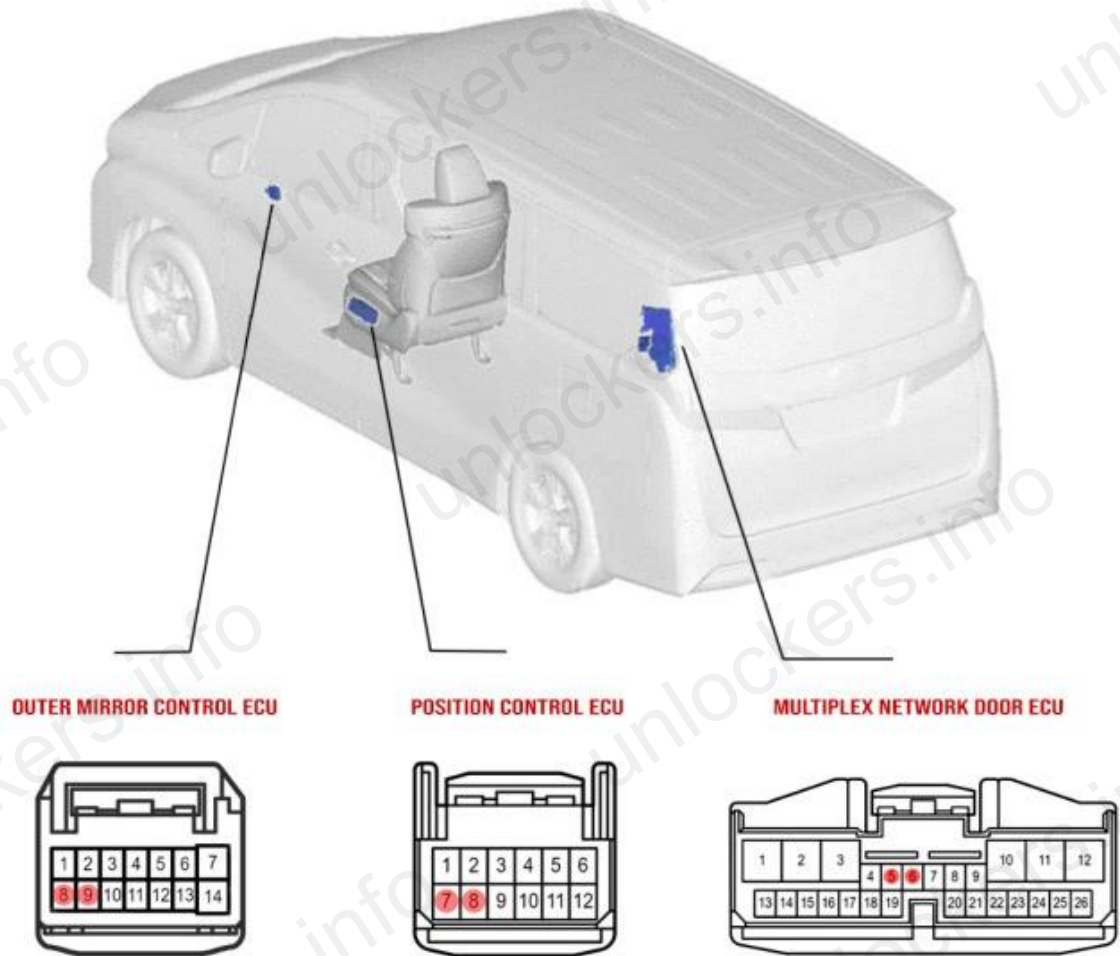

A8) Connection points for Lexus UX

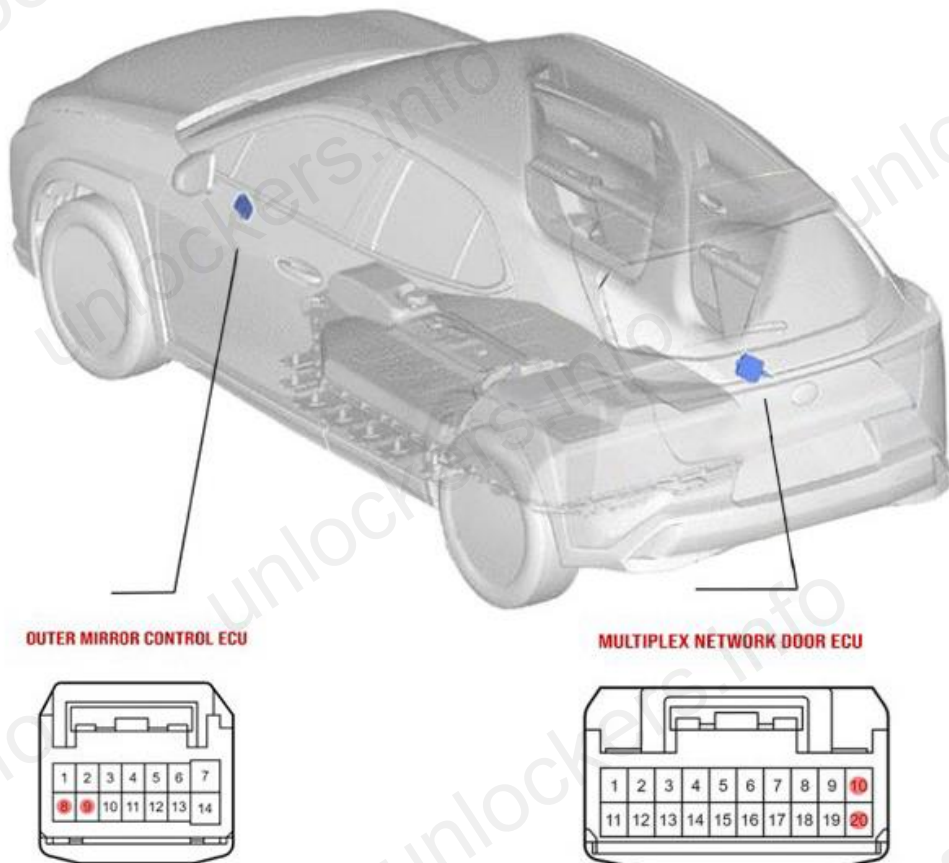

A9) Connection points for Toyota BZ4X

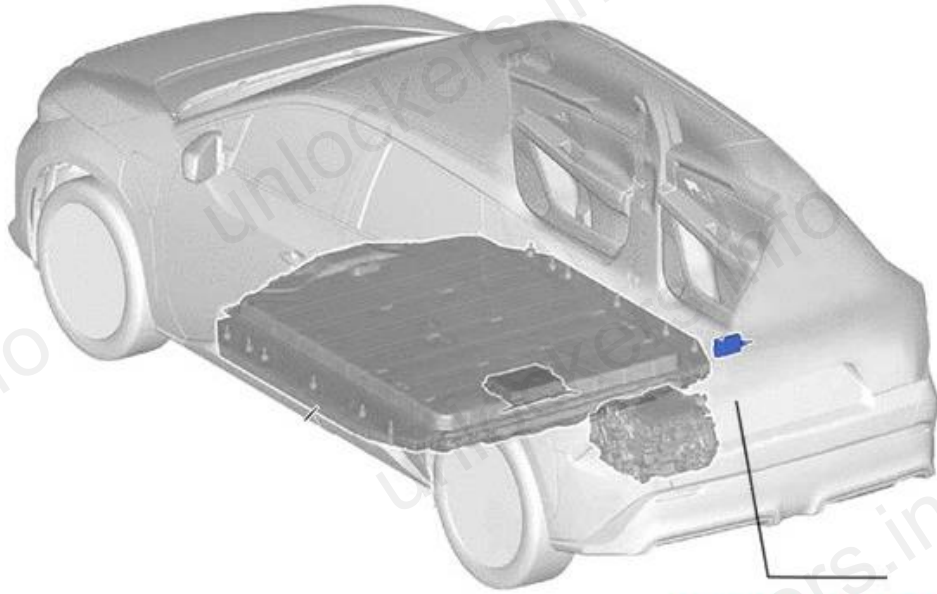

MULTIPLEX NETWORK DOOR ECU

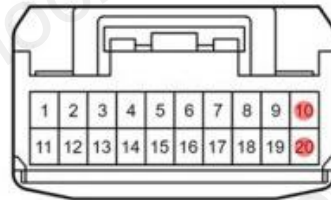

A10) Connection points for C-HR 2023



MULTIPLEX NETWORK DOOR ECU

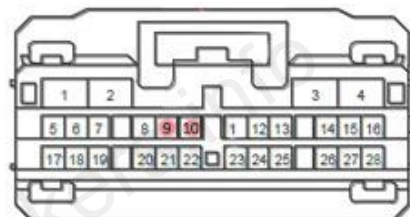



A13) Connection points for Toyota Corolla Cross

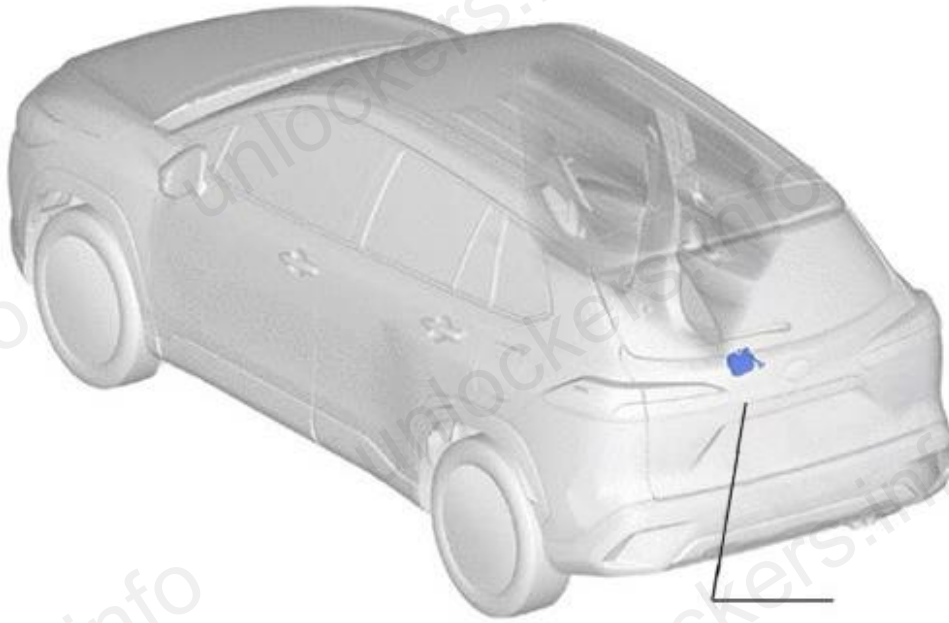

**MULTIPLEX NETWORK DOOR ECU**

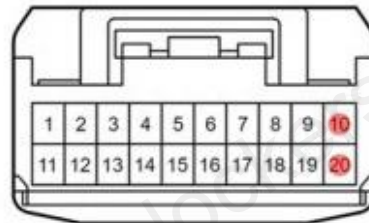

A14) Connection points for Land Cruiser 250



**OUTER MIRROR CONTROL ECU**



**MULTIPLEX NETWORK DOOR ECU**

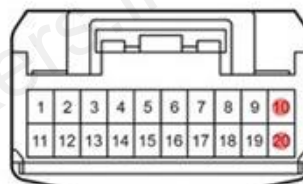

A15) Connection points for Land Cruiser 300



**OUTER MIRROR CONTROL ECU**

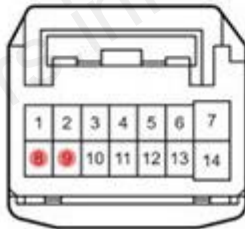

**MULTIPLEX NETWORK DOOR ECU**

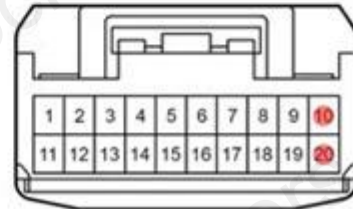

A16) Connection points for Toyota Mirai 2023

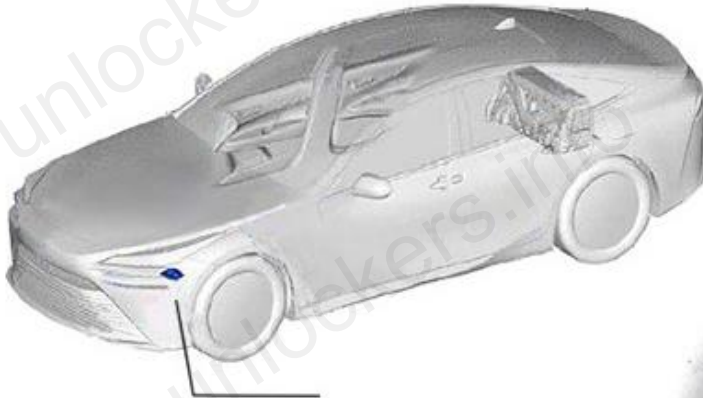

**HEADLIGHT**

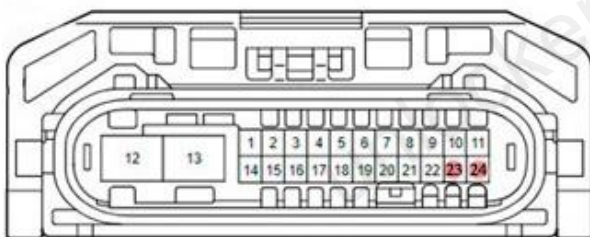

**MULTIPLEX NETWORK DOOR ECU**

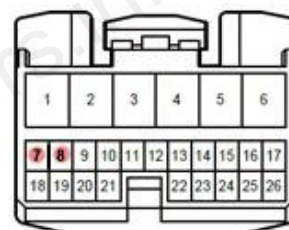

A17) Connection points for Toyota Prius 2024



MULTIPLEX NETWORK DOOR ECU

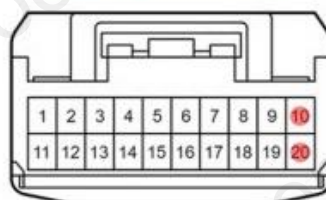

A18) Connection points for Toyota RAV4 PHV



HEADLIGHT

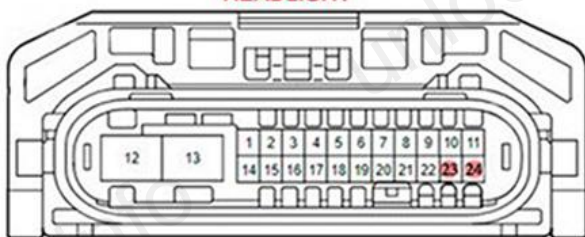

MULTIPLEX NETWORK DOOR ECU

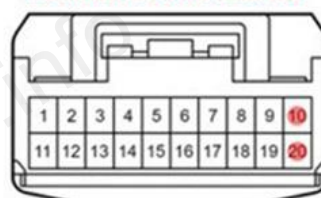

## A19) Connection points for Toyota Yaris Cross



**MULTIPLEX NETWORK DOOR ECU**

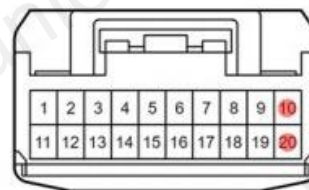

### **MODEL LIST**

Lexus		
Model	Year	Key
ES 300	2022+	BA-B9
GX550	2023+	BA-B9
LX600	2022+	BA-B9
NX	2022+	BA-B9
NX450h+ Hybrid	2023+	BA-B9
RX	2022+	BA-B9
RX450h+ Hybrid	2024+	BA-B9
RZ450e	2023+	BA-B9
TX	2023+	BA
TX Plug-in Hybrid	2023+	BA
TX 500h F - Sport	2023+	BA
UX	2023+	BA-B9
LBX	2024+	BA
LM350/500h	2024+	

Toyota		
Alphard/ Vellfire	2023+	BA
BZ4X	2023+	BA
Crown	2023+	BA
Camry	2024+	HTBA
Camry XV80	2023+	BA
Corolla	2022+	HTBA
Corolla Cross	2022+	HTBA
Grand Highlander	2024+	BA
Harrier	2021+	BA
Hilux	2024+	HTBA
Land Cruiser 300	2022+	BA
Land Cruiser 250	2024+	BA
Mirai	2023+	BA
Noah/Voxy	2022+	BA
Prius	2023+	BA
Prius Prime	2023+	BA
Prius USA	2023+	HTBA
RAV4 Plug-in Hybrid	2021+	BA
RAV4 Prime Hybrid	2021+	BA
Sequoia	2023+	BA
Sienna	2023+	BA
Tacoma	2023+	BA
Tacoma i-Force MAX	2023+	BA
Tundra	2023+	BA
Tundra i-Force MAX	2023+	BA
Venza	2023+	BA
Yaris	2021+	HTBA
Yaris Cross	2022+	HTBA

**Attention!!! This device is intended for legal use for demonstrating anti-theft protection of vehicles, necessary for the legal evacuation of vehicles from unauthorized parking by auto service personnel and towing services. Any misuse of the device for illegal purposes is punishable by law!**